

Fluorescent Rocks & Minerals

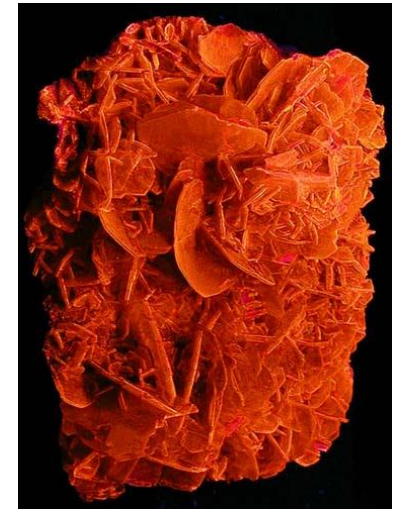

*Auckland Teacher's Day
Dec 4th 2020*

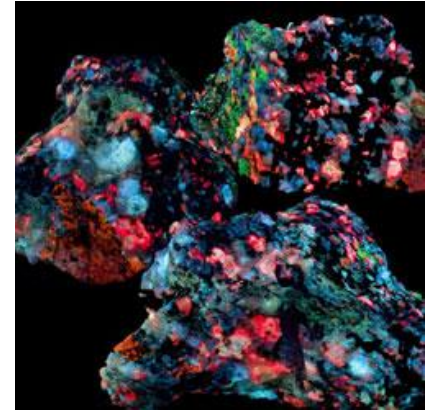
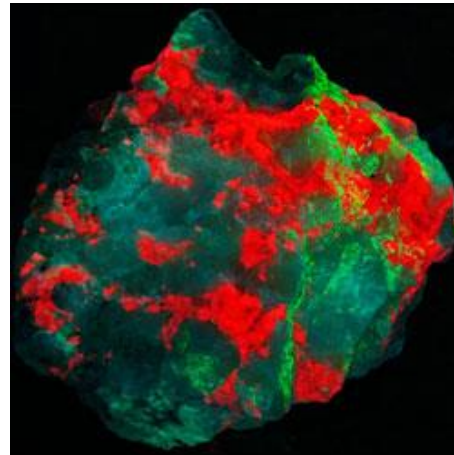
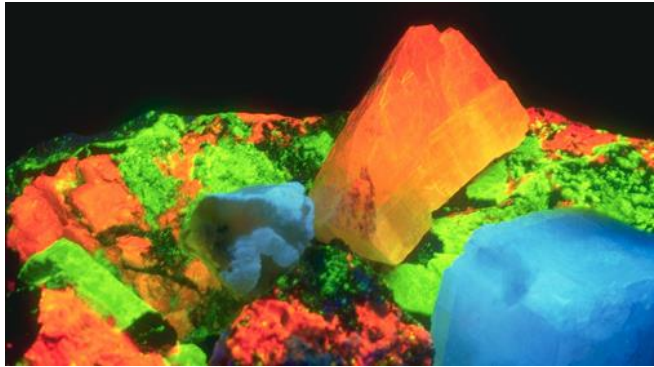

Martyn P. Coles

Definitions and Background

- **LUMINESCENCE** defined as:

"Light, or a glow, emitted by a luminescent (cool) object or surface"

(Oxford English Dictionary)

- an energy source promotes an electron of an atom from its "ground" (lowest-energy) state into an "excited" (higher-energy) state
- the electron gives back the energy in the form of light so it can fall back to its "ground" state

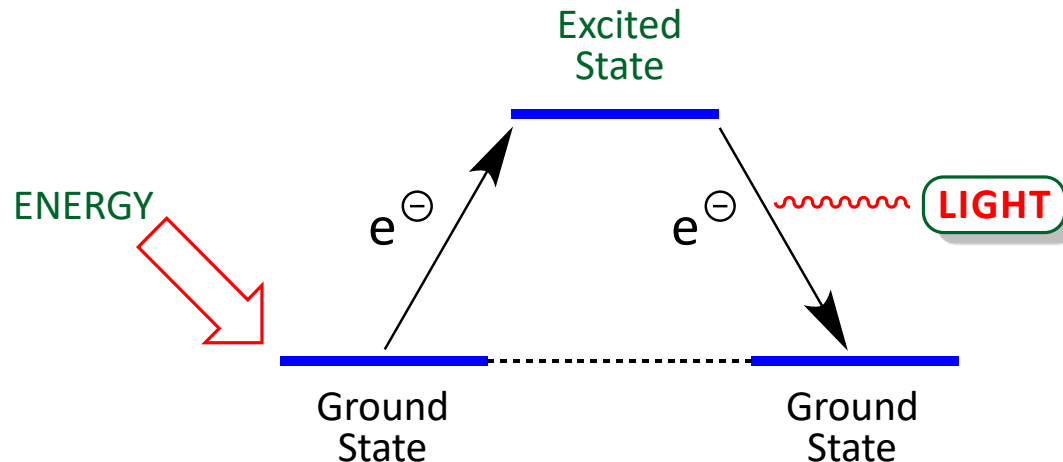

Types of Luminescence

CHEMILUMINESCENCE : luminescence where the energy is supplied by chemical reactions

For example - Glow-sticks



(<http://www.neonhusky.com>)

- typically the reaction of hydrogen peroxide with a solution of phenyl oxylate ester and a dye molecule

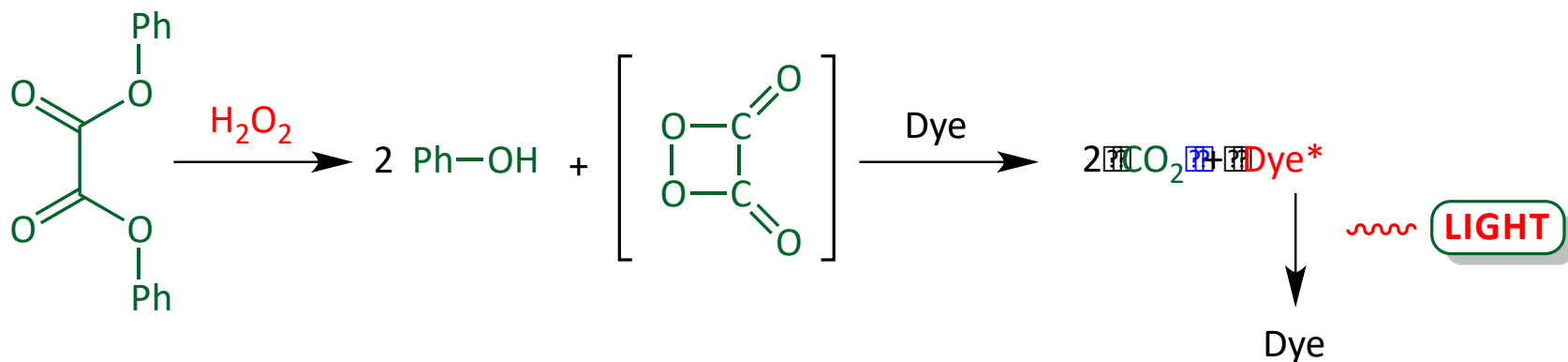

Types of Luminescence

BIOLUMINESCENCE : luminescence where the chemical reactions occur in living things (a type of **Chemiluminescence**)

For example – Glow Worm (*Lampyris Noctiluca*)

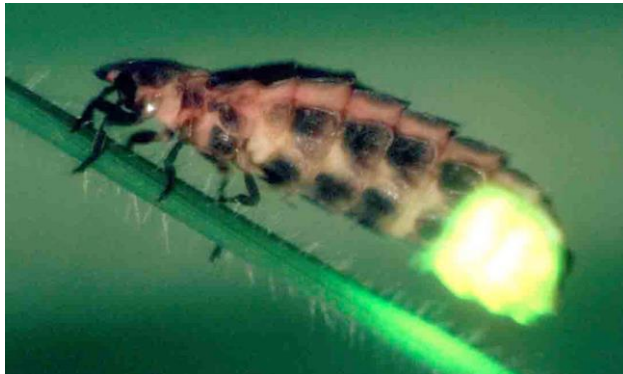

(<http://www.wildinbritain.co.uk>)

- chemical responsible : **LUCIFERIN**

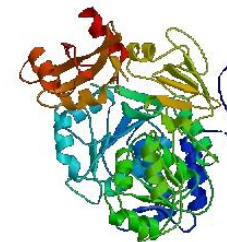
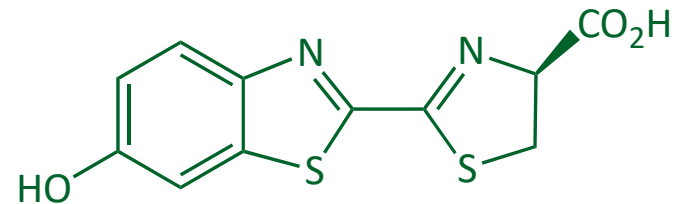

- enzyme (**LUCIFERASE**) catalyses oxidation of luciferin to give inactive oxyluciferin and **light**

Luciferin
 $+ \text{O}_2$

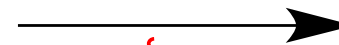

Oxyluciferin

LIGHT

New Zealand's own

Arachnocampa Luminosa

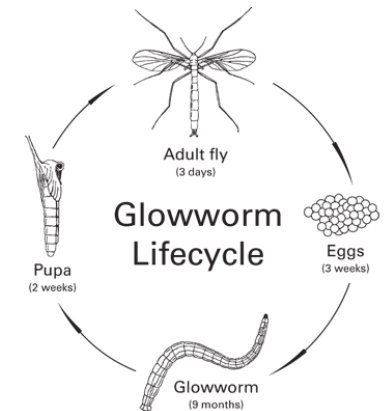

Waitomo Glowworm Caves
 (can also be seen in Zealandia / Karori...)

Fluorescence

FLUORESCENCE : luminescence where the energy is supplied by electromagnetic radiation

"The coloured luminosity produced in some transparent bodies by the direct action of light, esp. of the violet and ultra-violet rays; the property, in certain substances, of rendering the ultra-violet rays visible, so as to produce this phenomenon"

(Oxford English Dictionary)



Eu³⁺ vis

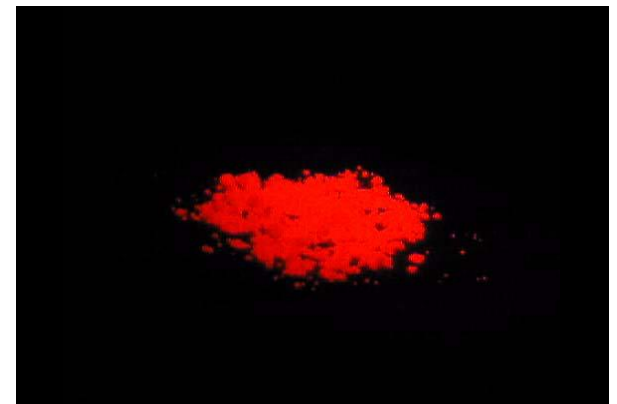
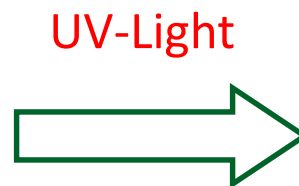

Eu³⁺ UV

Electromagnetic Spectrum

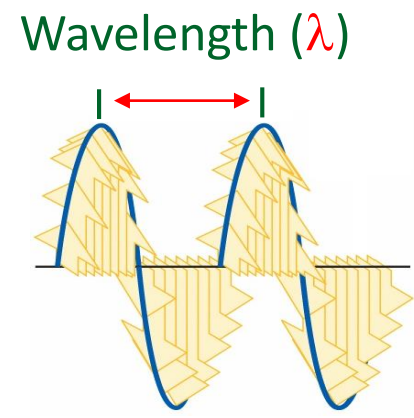
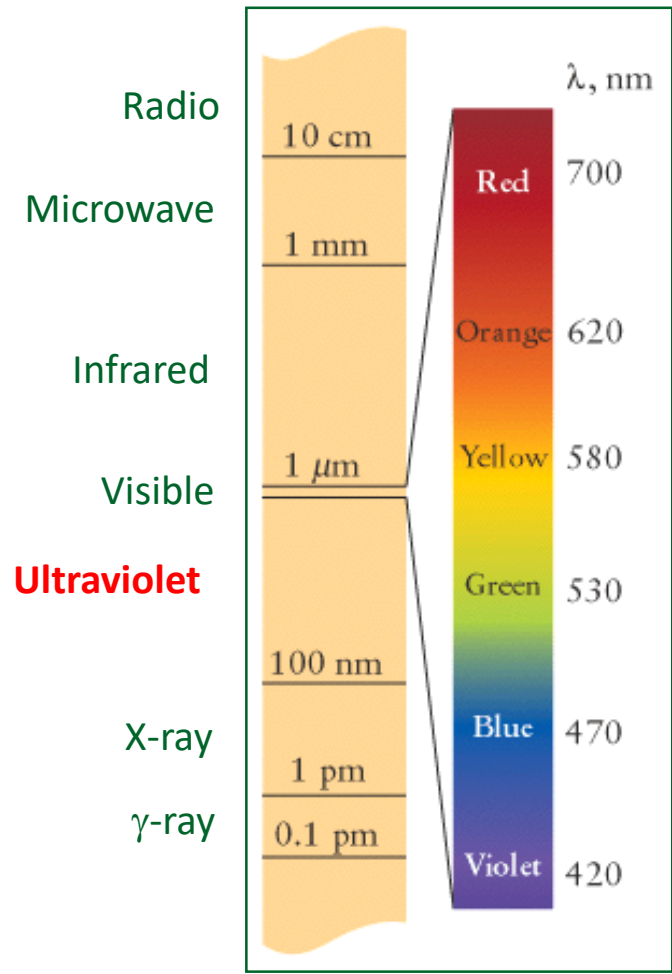

$$\lambda \nu = c$$

$$E = h \nu$$

$$E = \frac{h c}{\lambda}$$

- λ inverse relationship with frequency, ν
i.e.
 as λ increases ν decreases
- λ inverse relationship with energy, E
i.e.
 as λ increases E decreases

Ultraviolet : $\lambda = \sim 400 - 10 \text{ nm}$

(*i.e.* shorter than that of visible light)

REMEMBER RULAR

Excitation and Decay

- radiative decay process
- more common is a non-radiative decay
i.e. transfer of energy to rotational, vibrational or translational energy
- fluorescence always occurs at lower frequency (higher wavelength, lower energy)
- therefore absorption from UV light emitted in the visible region, hence we see colours

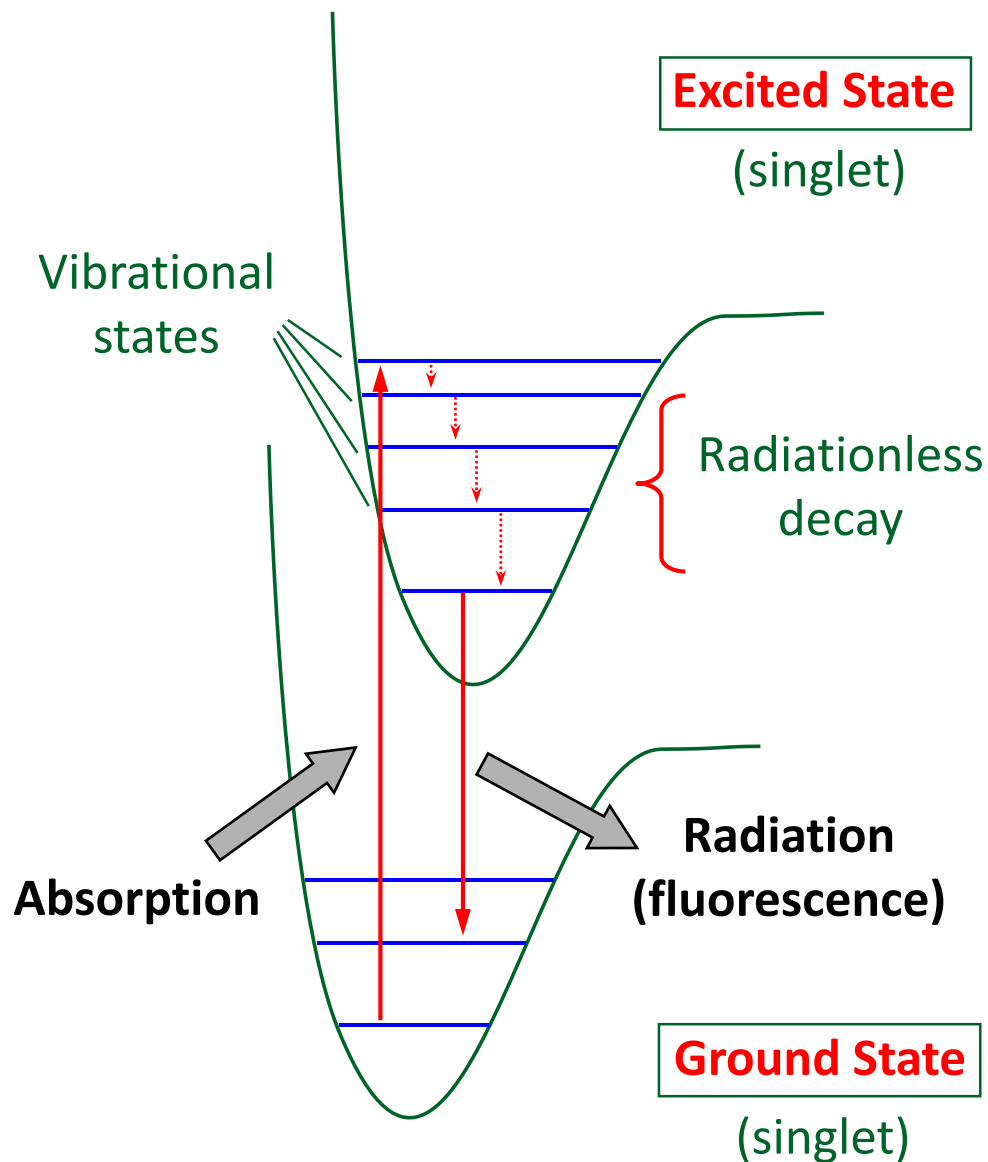

Fluorescent Minerals

- more than 5000 different mineral species currently known
- over 500 of them are known to fluoresce *in some samples*
- some minerals are inherently fluorescent

e.g.

scheelite - CaWO_4

autunite - $\text{Ca}(\text{UO}_2)_2[\text{PO}_4]_2 \cdot 10\text{-}12 \text{H}_2\text{O}$

benitoite - $\text{BaTi}[\text{Si}_3\text{O}_9]$



(<http://www.webmineral.com>)

- others are only reactive when certain impurities (**activators**) are present in certain proportions

e.g.

fluorite – CaF_2 (+ rare earth' s)

halite – NaCl (+ Mn & Pb)

calcite – CaCO_3 (+ Mn, Pb, Ba, Hg...)



(<http://www.ukminingventures.com>)

Inherent Fluorescence: Scheelinite

- named after Karl Wilhelm Scheele (1742-1786) a Swedish chemist, who proved the existence of tungstic oxide in the mineral in 1781
- molecular formula $\text{Ca}[\text{WO}_4]$
- composed of $[\text{WO}_4]^{2-}$ tetrahedra and Ca^{2+} ions
- industrially important ore of tungsten
- gives blue-white fluorescence (SWUV)

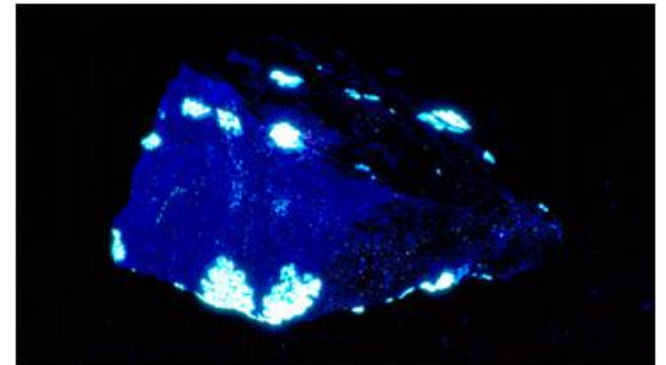
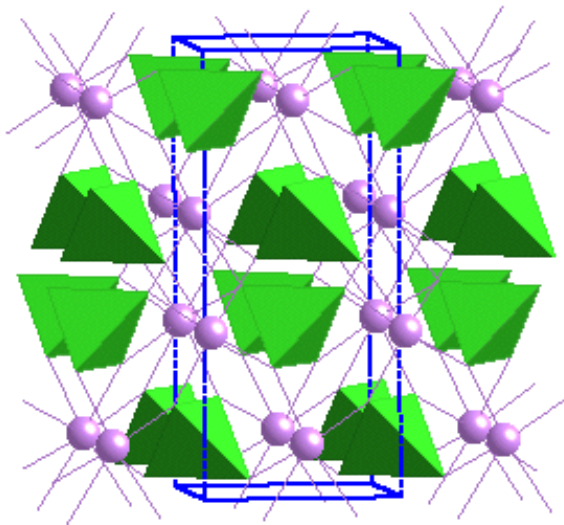

Origins of Fluorescence

- d -electron count on the tungsten = zero (d^0 centre)
- origin of fluorescence **L**igand **M**etal **C**harge **T**ransfer (**LMCT**)
- same process gives $[\text{MnO}_4]^-$ intense purple colour in solution
- the mineral actually forms a solid-solution with the molybdenum analogue, $\text{Ca}[\text{MoO}_4]$
- known as **POWELLITE** and also fluorescent (this time **YELLOW**)

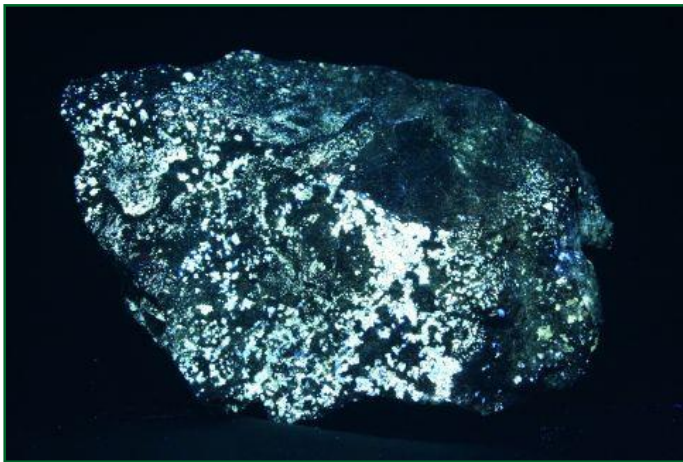

(James at <http://www.picasaweb.google.com>)



(© Rob Lavinski: <http://www.mindat.org>)

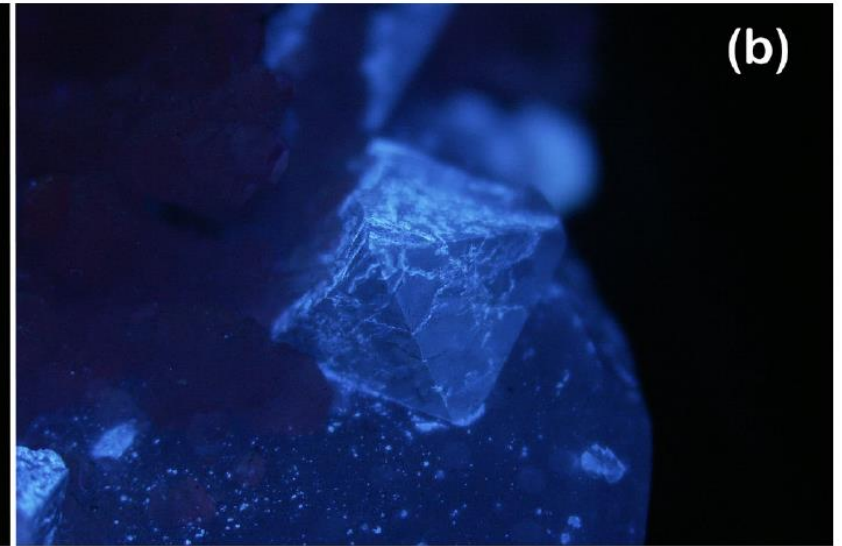

Scheelite in New Zealand

(<http://www.teara.govt.nz>)

- found in quartz veins in several localities (often in association with gold)
- small mines worked at **Macraes /Glenorchy** (Otago) and **Wakamarina** (Marlborough)
- recovery of tungsten is uneconomic at current prices



- a worldwide shortage of tungsten during the 2nd World War led the government to take over two of the scheelite mines in **Glenorchy**
- once the price dropped (1944–45) the mines reverted to private ownership

Miner uses a petrol-driven drill to break up scheelite ore in the early 1950s
A gas mask protects against the petrol fumes and dust. The site was high in the mountains above Glenorchy.

Glenorchy... part of the history



Inside scheelite mine tunnel



(University of Otago, Geology Department)

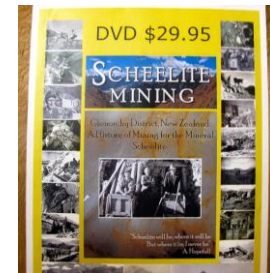

Quartz veins from the Macraes area, viewed under ultra-violet light. The scheelite glows white-blue, while the quartz is dark purple

Glenorchy... part of the history



(Don't?) leave the door open...

Radioactive Minerals (U and Th)

- abundance in crustal rocks : **URANIUM** – 1800
 (ppb or mg/1000 kg) **THORIUM** – 6000

Calcium – 50000000
 Tungsten – 1100

- most common ore = **URANITITE** (formula = UO_2)
- impure form referred to as "*pitchblende*"
- same solid-state structure as Fluorite (CaF_2)

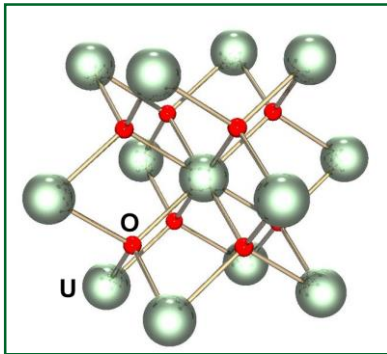

NON-FLUORESCENT!



(<http://varifrank.com>)

- Marie Curie noted that pitchblende emitted approximately $4 \times$ as much radiation as predicted for the amount of uranium
- led to discovery of polonium (Po) and radium (Ra)

Fluorescent Uranium Minerals

- often based on the **URANYL ION**, $[\text{UO}_2]^{2+}$

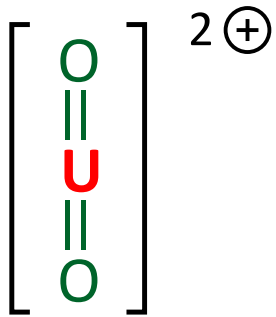

- very stable linear dication
- trans*-oxygen atoms
- many molecular compounds incorporate this unit

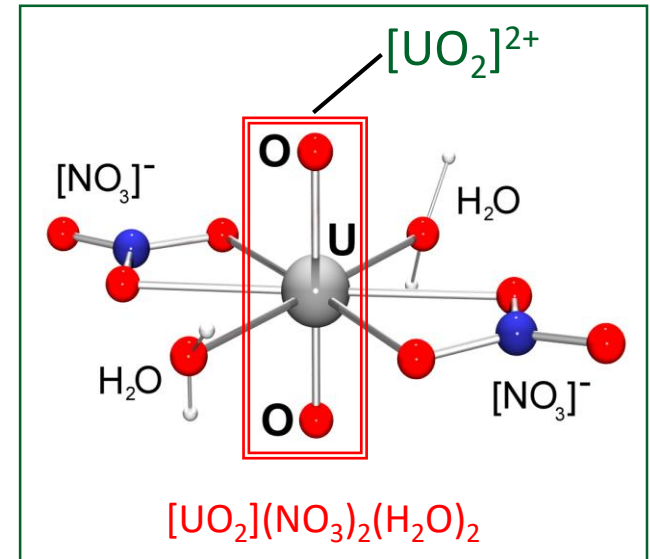

autunite	: $\text{Ca}(\text{UO}_2)_2[\text{PO}_4]_2 \cdot 10\text{-}12 \text{H}_2\text{O}$
(torbernite)	: $\text{Cu}(\text{UO}_2)_2[\text{PO}_4]_2 \cdot 8\text{-}12 \text{H}_2\text{O}$
uranocircite	: $\text{Ba}(\text{UO}_2)_2[\text{PO}_4]_2 \cdot 12 \text{H}_2\text{O}$
saléeite	: $\text{Mg}(\text{UO}_2)_2[\text{PO}_4]_2 \cdot 10 \text{H}_2\text{O}$
zeunerite	: $\text{Cu}(\text{UO}_2)_2[\text{AsO}_4]_2 \cdot 10\text{-}16 \text{H}_2\text{O}$

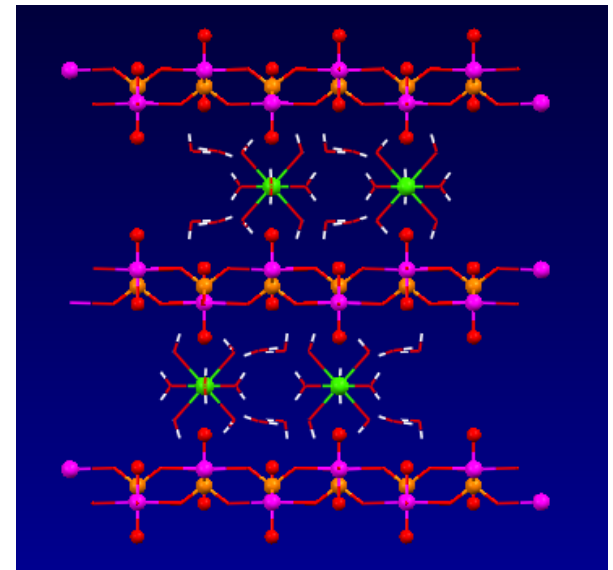

Examples of Uranium Minerals

(<http://www.mindat.org>)

Saléeite



Uranocircite



Zeunerite



Curite

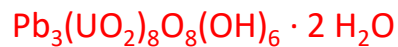

Becquerelite



Cuprosklowdoskite



Fluorescence of U Minerals

Autunite

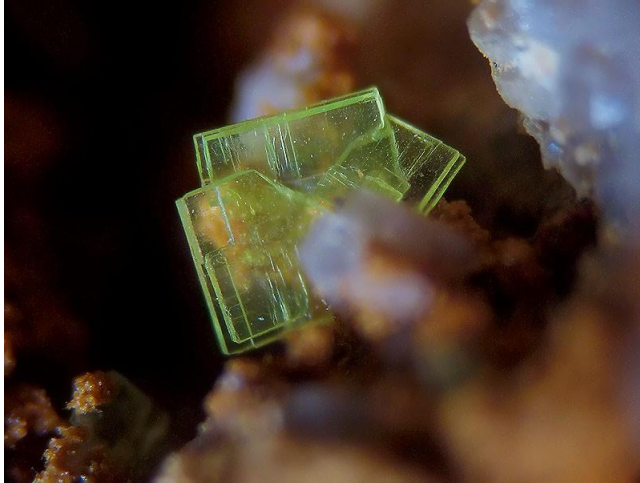

Andersonite

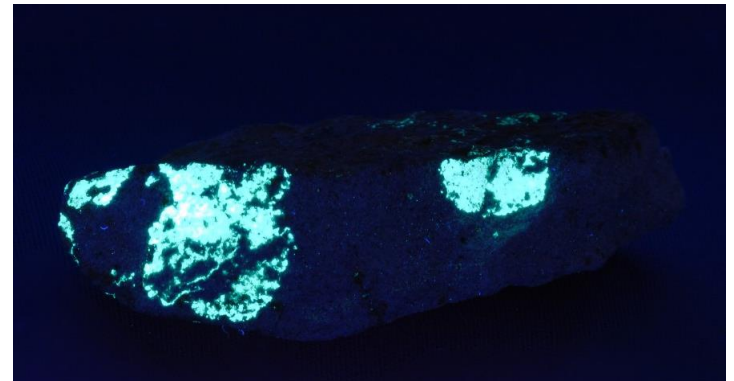

Uranium-rush in New Zealand

(<http://www.teara.govt.nz>)

- originally inspired by British / American demand for uranium WWII
- New Zealand originally not considered promising enough to include
- the first uranium survey was headed by Ernest Marsden, who was head of the Department of Scientific and Industrial Research (**DSIR**)
- most promising source identified as 'black sand' concentrates of gold dredges on **Gillespies Beach** (near Franz Josef)



Uranium-rush in New Zealand

(<http://www.teara.govt.nz>)

- the Department of Scientific and Industrial Research (DSIR) chartered the government ship the *New Golden Hind* to survey granitic rocks
- nearly 1,600 km of coast, sands and gravels revealed no significant deposits of radioactive material
- by the 1950's New Zealand Geological Survey enlisted the help of the general public with the publication of a booklet:
'Prospecting for Radioactive Minerals in New Zealand'
- in 1955 two prospectors (Frederick Cassin and Charles Jacobsen) discover radioactive rocks in a road cutting near **Hawks Crag (Buller Gorge)**

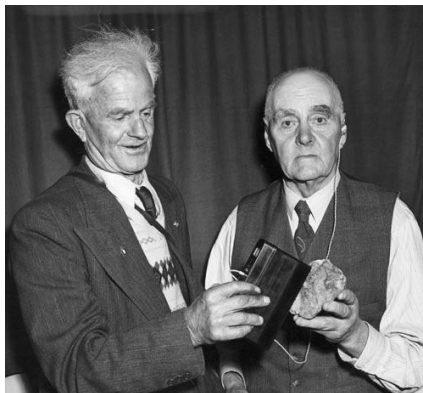
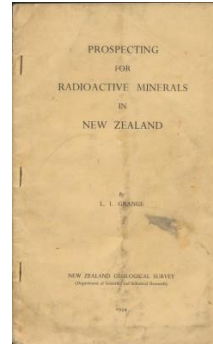

“I believe that it is possible we have discovered the second most concentrated uranium deposit in the world”



Uranium-rush in New Zealand

(<http://www.teara.govt.nz>)

- fame, if not fortune? Cassin and Jacobsen received £100 (1956) and a further £400 (1958) for their discovery
- triggered a 'uranium-rush'
- however, more detailed analysis revealed the original discovery was an anomaly
- further samples contained only 0.01-0.25x the levels of the first sample
- despite further investments and government support, concentrations of uranium oxide were too low to be financially viable
- as an aside, the new mineral **Huttonite** (ThSiO_4) was discovered at Gillespie's beach
- dull white fluorescence

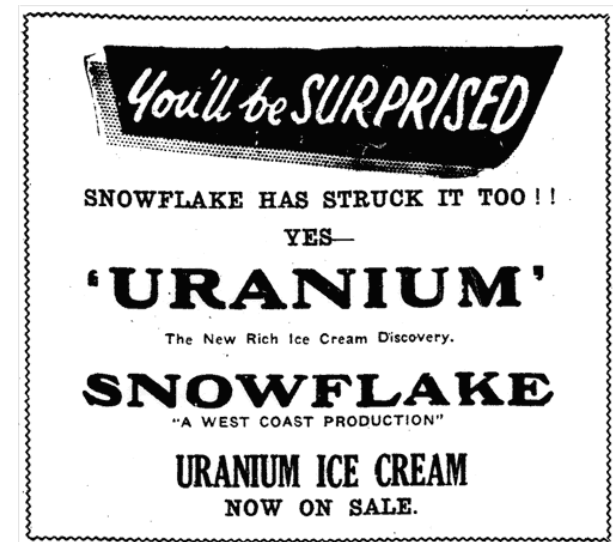

Uranium Minerals of New Zealand

(<http://www.mindat.org>)

Autunite (Hawks Crag, Westport)

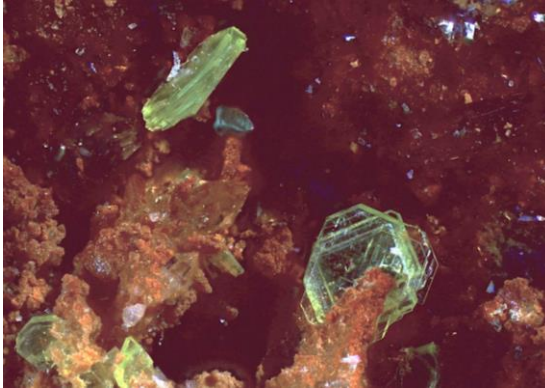

Metatorbernite (Hawks Crag, Westport)



Torbernite (Hawks Crag, Westport)

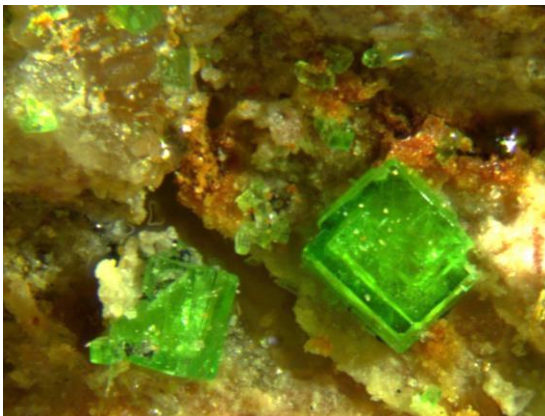

432

[Aug.

**URANIUM MINERALIZATION IN THE HAWKS CRAG
BRECCIA OF THE LOWER BULLER GORGE REGION,
SOUTH ISLAND, NEW ZEALAND**

By A. C. BECK, J. J. REED, and R. W. WILLETT, New Zealand
Geological Survey, Department of Scientific and Industrial Research

(Received for publication, 20 June 1958)

602

[August

**GEOCHEMICAL PROSPECTING FOR URANIUM IN
THE LOWER BULLER GORGE, NEW ZEALAND**

By A. WODZICKI, New Zealand Geological Survey, Department of
Scientific and Industrial Research, Lower Hutt

(Received for publication, 24 April 1959)

Fluorite – Where it all began?

"I am almost inclined to coin a word and call the appearance *fluorescence*, from fluor-spar, as the analogous term *opalescence* is derived from the name of a mineral"

PROF. STOKES in *Phil. Trans.* 1852

- molecular formula CaF_2
- very widespread mineral worldwide (6284 recorded locations – including two in New Zealand)
- industrially important as a flux in the steel industry
- name actually derives from Latin '*fluere*' meaning to flow
- also used in the manufacture of hydrofluoric acid

i.e.

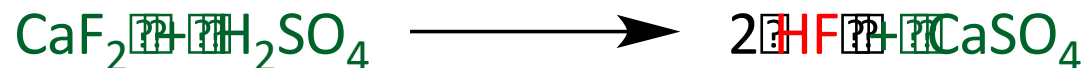

Activators hold the key...

- small amounts of ‘impurities’ (not a constituent part of the mineral) responsible for the fluorescence

fluorite – CaF_2 (rare earth metals; hydrocarbons)

Rogerley Mine
(Weardale)

Eu^{2+}



Normal



Daylight



LWUV

Clay Center
(Ohio)



Daylight

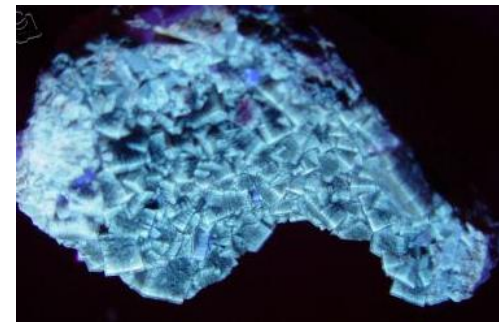

LWUV

Famous Locations

(<http://www.franklin-sterlinghill.com>)

Franklin – Sterling Hill, New Jersey, USA

*"fluorescent mineral capital
of the world"*

- more than 340 minerals, 80 of them fluorescent



Calcite/Willemite

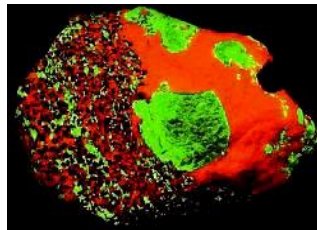
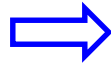

$\text{CaCO}_3 / \text{Zn}_2[\text{SiO}_4]$



Hardystonite

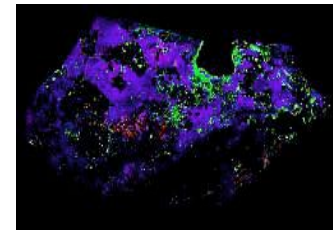
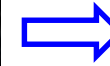

$\text{Ca}_2\text{Zn}[\text{Si}_2\text{O}_7]$



Esperite

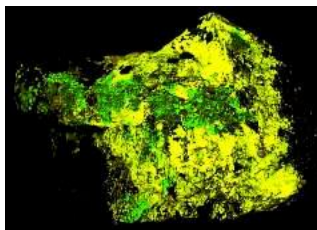
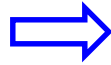

$\text{PbCa}_3\text{Zn}_4[\text{SiO}_4]_4$



Clinohedrite

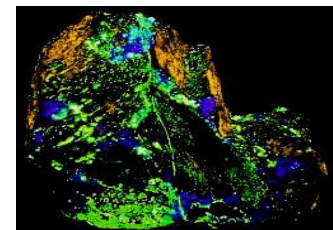

$\text{CaZn}[\text{SiO}_4] \cdot \text{H}_2\text{O}$



Barite

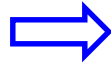

BaSO_4



Margarosanite



$\text{Pb}(\text{Ca}, \text{Mn}^{\text{II}})[\text{Si}_3\text{O}_9]$

Franklin, New Jersey, USA

(<http://www.luminousminerals.com>)

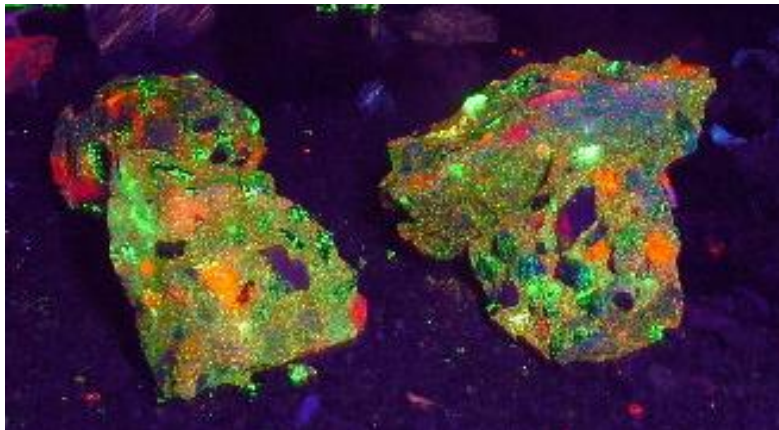

Fluorescent concrete!!

Tenebrescence

- the ability of minerals to change colour when exposed to sunlight (reversible photochromism)

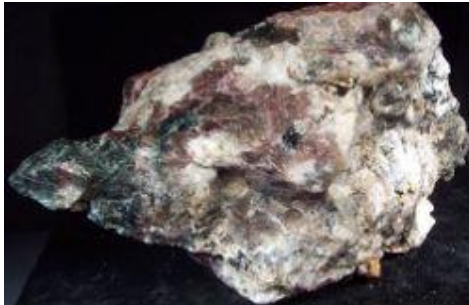

Natural Light

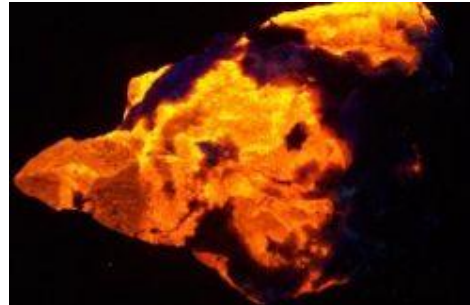

LWUV Light



Tenebrescence



Natural Light



Tenebrescence



Phosphorescence

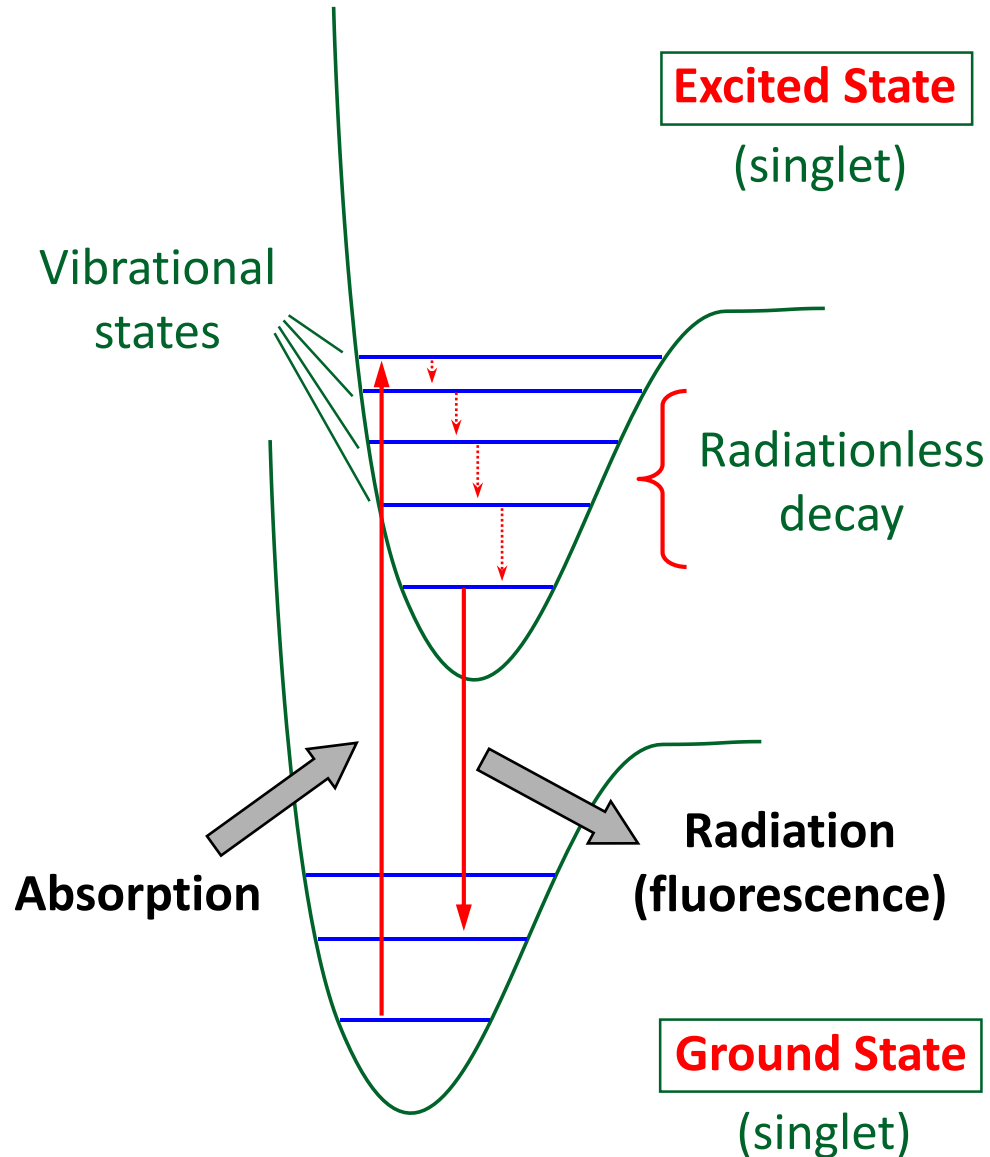

Phosphorescence

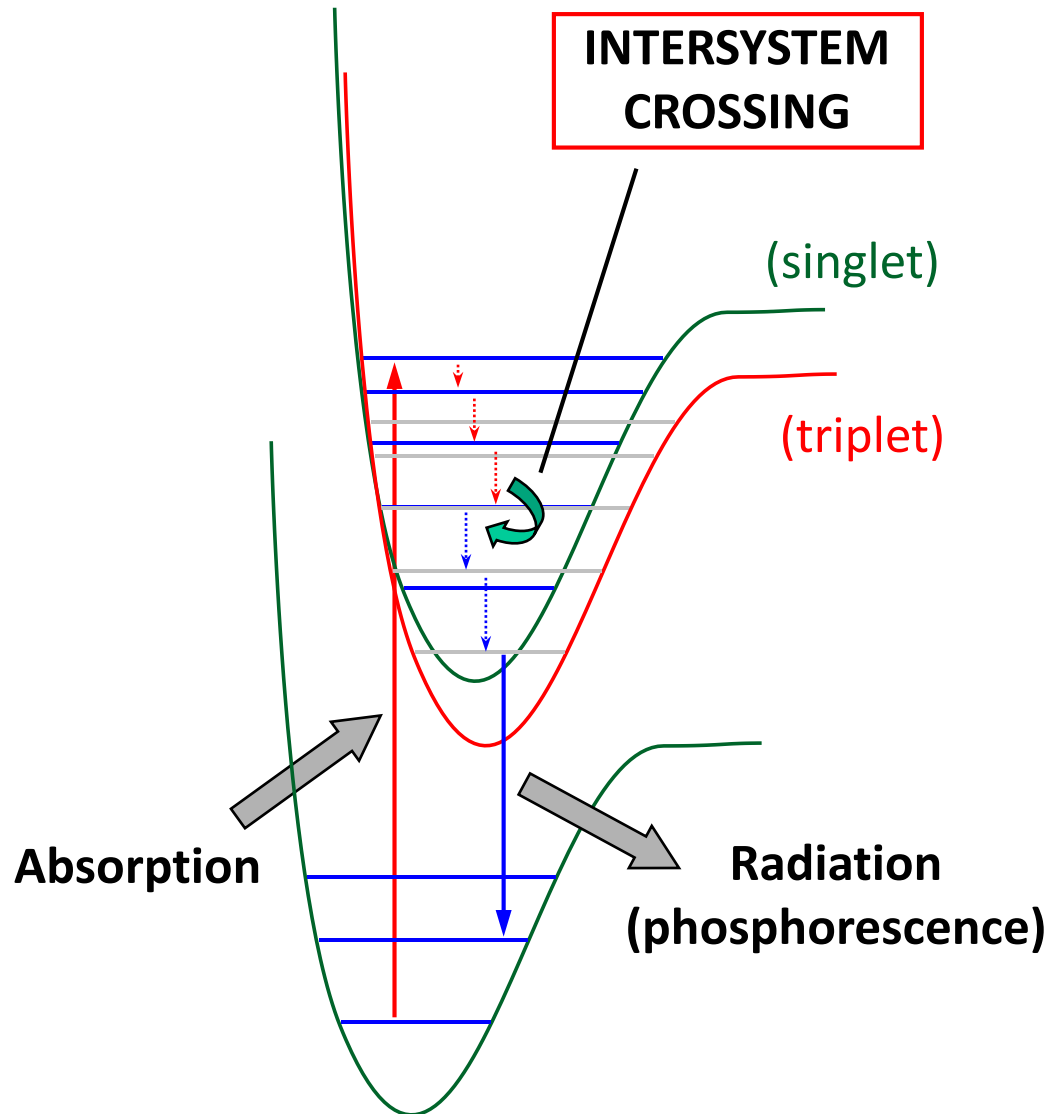

- closely related to fluorescence
- excited **triplet** state of similar energy
- during decay process **intersystem crossing** occurs to the triplet state
- decay from triplet to singlet is "forbidden" according to quantum mechanics

Phosphorescence

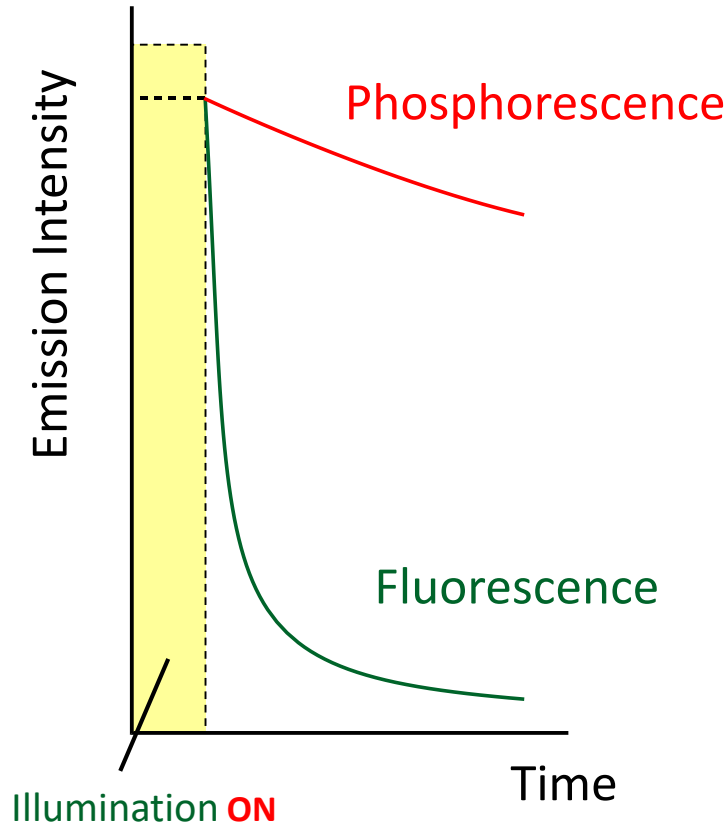

- although "forbidden" will still occur
- much slower timescale

EMISSION:

- fluorescence – nanoseconds
- phosphorescence – may persist for long periods (up to hours)

Organic Minerals?

MINERAL: a solid, naturally occurring, *usually inorganic* substance with a definite chemical composition and characteristic physical structure and properties (such as crystalline form)

Examples of 'organic' minerals:

Whewellite



(© Petr Fuchs: <http://www.mindat.org>)

Salammoniac



(© Weinrich Minerals Inc.: <http://www.mindat.org>)

Fluorescent Organic Minerals

Idrialite $C_{22}H_{14}$

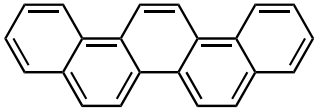

(aka picene)

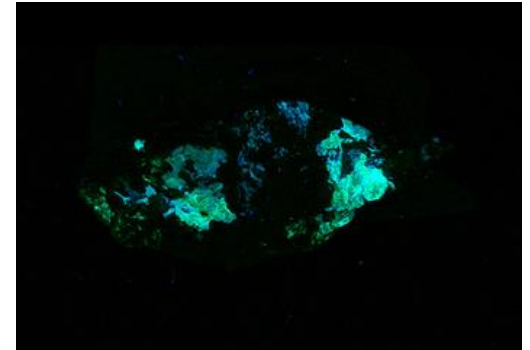
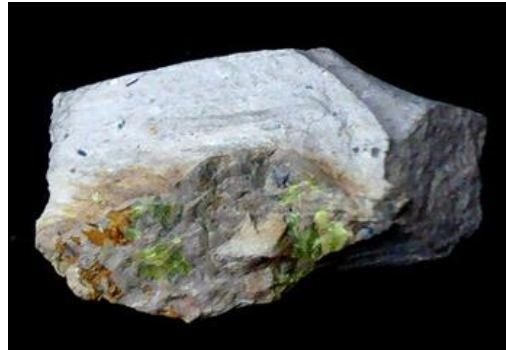

Carpathite $C_{24}H_{12}$

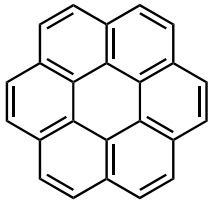

(aka coronene)

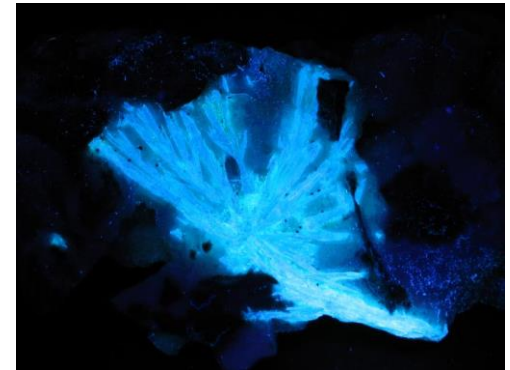

Origins of Tenebrescence

Mechanisms of Tenebrescence and Persistent Luminescence in Synthetic Hackmanite $\text{Na}_8\text{Al}_6\text{Si}_6\text{O}_{24}(\text{Cl},\text{S})_2$

Isabella Norrbo,[†] Pawel Gluchowski,[‡] Iko Hyppänen,[†] Tero Laihinen,^{†,§} Pekka Laukkanen,[⊥]
 Jaakko Mäkelä,^{§,⊥} Fikret Mamedov,^{||} Hellen S. Santos,^{†,§} Jari Sinkkonen,[†] Minnea Tuomisto,^{†,§}
 Antti Viinikanoja,[†] and Mika Lastusaari,^{*,†,||}

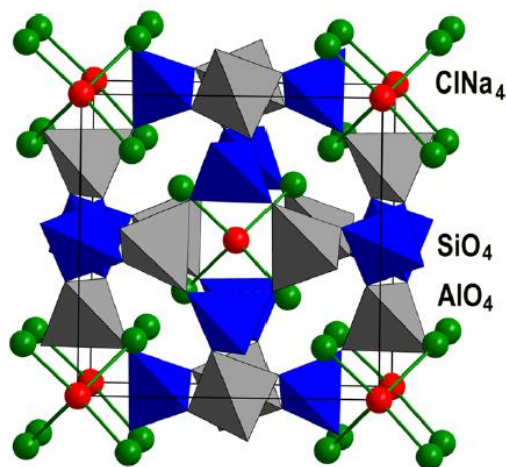

Unit Cell

